



**STRONG PARTNERS.
TOUGH TRUCKS.™**



THREE-WHEEL ELECTRIC COUNTERBALANCED LIFT TRUCKS

J1.5-2.0XNT

1500-2 000 KG



J1.5XNT, J1.6XNT, J1.8XNT, J2.0XNT

DISTINGUISHING MARKS	1.1	Manufacturer (abbreviation)	
	1.2	Manufacturer's type designation	
	1.3	Drive: electric (battery or mains), diesel, petrol, fuel gas	
	1.4	Operator type: hand, pedestrian, standing, seated, order-picker	
	1.5	Rated capacity/rated load	Q (t)
	1.6	Load centre distance	c (mm)
	1.8	Load distance, centre of drive axle to fork	x (mm)
	1.9	Wheelbase	y (mm)

WEIGHTS	2.1	Service weight <input type="checkbox"/>	kg
	2.2	Axle loading, laden front/rear <input type="checkbox"/>	kg
	2.3	Axle loading, unladen front/rear <input type="checkbox"/>	kg

TYRES / CHASSIS	3.1	Tyres: P=pneumatic, C=cushion, SE=superelastic	
	3.2	Tyre size, front	
	3.3	Tyre size, rear	
	3.5	Wheels, number front/rear (x = driven wheels)	
	3.6	Tread, front	b ₁₀ (mm)
	3.7	Tread, rear	b ₁₁ (mm)

DIMENSIONS	4.1	Tilt of mast/fork carriage forward/backward	α / β (°)
	4.2	Height, mast lowered	h ₁ (mm)
	4.3	Free lift \uparrow	h ₂ (mm)
	4.4	Lift \uparrow	h ₃ (mm)
	4.5	Height, mast extended \uparrow	h ₄ (mm)
	4.7	Height of overhead guard (cabin) \blacksquare	h ₆ (mm)
	4.7.1	Cab height (open cab)	
	4.8	Seat height relating to SIP/stand height \odot	h ₇ (mm)
	4.12	Coupling height	h ₁₀ (mm)
	4.19	Overall length	l ₁ (mm)
	4.20	Length to face of forks	l ₂ (mm)
	4.21	Overall width \boxplus	b ₇ /b ₂ (mm)
	4.22	Fork dimensions ISO 2331	s/e/l (mm)
	4.23	Fork carriage ISO 2328, class/type A, B	
	4.24	Fork carriage width \uparrow	b ₃ (mm)
	4.31	Ground clearance, laden, below mast	m ₁ (mm)
	4.32	Ground clearance at centre of wheelbase \boxtimes	m ₂ (mm)
	4.33	Load dimension b ₁₂ x l ₆ crossways	b ₁₂ x l ₆ (mm)
	4.34	Aisle width predetermined load dimensions	A _{st} (mm)
	4.34.1	Aisle width for pallets 1000 x 1200 crossways \blacklozenge	A _{st} (mm)
	4.34.2	Aisle width for pallets 800 x 1200 lengthways \blacklozenge	A _{st} (mm)
4.35	Turning radius	W ₈ (mm)	
4.36	Internal turning radius	b ₁₃ (mm)	
4.41	90° intersecting aisle (With pallet W = 1200mm, L = 1000mm)	(mm)	
4.42	Step Height (from ground to running board)	(mm)	
4.43	Step Height	(mm)	

PERFORMANCE DATA	5.1	Travel speed, laden/unladen \triangle	km/h
	5.1.1	Travel speed, laden/unladen, backwards	km/h
	5.2	Lift speed, laden/unladen	m/s
	5.3	Lowering speed, laden/unladen	m/s
	5.5	Drawbar pull, laden/unladen **	N
	5.6	Max. drawbar pull, laden/unladen ***	N
	5.7	Gradeability, laden/unladen \uparrow ****	%
	5.8	Max. gradeability, laden/unladen \uparrow ***	%
	5.9	Acceleration time, laden/unladen \triangle	s
	5.10	Service brake	

ELECTRIC ENGINE	6.1	Drive motor rating S2 60 min	kW
	6.2	Lift motor rating at S3 15%	kW
	6.3	Battery according to DIN 43531/35/36 A, B, C, no	
	6.4	Battery voltage/nominal capacity K5	(V)/(Ah)
	6.5	Battery weight \blacktriangle	kg
	6.6	Energy consumption according to VDI cycle \triangle	kWh/h @Nr of Cycles

ADDITIONAL DATA	8.1	Type of drive unit	
	10.1	Operating pressure for attachments	bar
	10.2	Oil volume for attachments \blacklozenge	l/min
	10.3	Hydraulic oil tank, capacity	l
	10.7	Sound pressure level at the driver's seat l _{pAZ} \boxplus	dB(A)
	10.8	Towing coupling, type DIN	

HYSTER		HYSTER		HYSTER	
J1.5XNT (SWB)		J1.6XNT (SWB)		J1.6XNT (MWB)	
Electric (Battery)		Electric (Battery)		Electric (Battery)	
Seated		Seated		Seated	
1.5		1.6		1.6	
500		500		500	
326		326		326	
1290		1290		1386	

2971		3083		3083	
3892	580	4096	587	4050	633
1430	1541	1470	1613	1495	1588

SE		SE		SE	
18 x 7-8		18 x 7-8		18 x 7-8	
15 x 4.5-8		15 x 4.5-8		15 x 4.5-8	
2X	2	2X	2	2X	2
889		889		889	
194		194		194	

5		5		5		5		
2230		2230		2230		2230		
100		100		100		100		
3320		3320		3320		3320		
3898		3898		3898		3898		
2070		2070		2070		2070		
2085		2085		2085		2085		
919		919		919		919		
500		500		500		500		
2807		2807		2903		2903		
1807		1807		1903		1903		
1050 \boxplus		1050 \boxplus		1050 \boxplus		1050 \boxplus		
40	80	1000	40	80	1000	40	80	1000
2A		2A		2A		2A		
907		907		907		907		
70		70		70		70		
100		100		100		100		
1000 x 1200		1000 x 1200		1000 x 1200		1000 x 1200		
3134		3134		3232		3232		
3134		3134		3232		3232		
3257		3257		3355		3355		
1479		1479		1577		1577		
0		0		0		0		
1718		1718		1754		1754		
557		557		557		557		
484		484		484		484		

16		16		16		16	
16		16		16		16	
0.43	0.59	0.43	0.59	0.43	0.59	0.43	0.59
0.50	0.47	0.50	0.47	0.50	0.47	0.50	0.47
3406	3680	3406	3680	3406	3680	3406	3680
11415	11690	11415	11690	11415	11690	11415	11690
11	16	11	16	11	16	11	16
25	34	25	34	25	35	25	35
4.6	4.1	4.6	4.1	4.6	4.1	4.6	4.1
Electric		Electric		Electric		Electric	

2x 5.0		2x 5.0		2x 5.0	
12		12		12	
DIN 43531-A		DIN 43531-A		DIN 43531-A	
48	500	48	500	48	625
673	743	673	743	813	899
3.9		4.2		4.2	

Electric transmission		Electric transmission		Electric transmission	
180		180		180	
40		40		40	
16.8		16.8		16.8	
69		69		69	
Pin		Pin		Pin	

Specification data is based on VDI 2198. ** 60 minute rating *** 5 minute rating **** 30 minute rating

HYSTER		HYSTER		HYSTER		HYSTER		HYSTER		DISTINGUISHING MARKS	
J1.6XNT (LWB)		J1.8XNT (MWB)		J1.8XNT (LWB)		J2.0XNT (MWB)		J2.0XNT (LWB)			1.2
Electric (Battery)		Electric (Battery)		Electric (Battery)		Electric (Battery)		Electric (Battery)			1.3
Seated		Seated		Seated		Seated		Seated			1.4
1.6		1.8		1.8		2.0		2.0			1.5
500		500		500		500		500			1.6
326		321		321		321		321			1.8
1494		1386		1494		1386		1494		1.9	

3258		3335		3331		3602		3436		2.1
4056	802	4496	640	4435	695	4941	661	4788	648	2.2
1571	1687	1628	1707	1646	1685	1755	1847	1689	1747	2.3

PSS		PSS		PSS		PSS		PSS		TIRES / CHASSIS	
18 x 7-8		200/50-10		200/50-10		200/50-10		200/50-10			3.1
15 x 4.5-8		15 x 4.5-8		15 x 4.5-8		15 x 4.5-8		15 x 4.5-8			3.2
2X	2	2X	2	2X	2	2X	2	2X	2		3.3
889		908		908		908		908			3.5
194		194		194		194		194			3.6
194		194		194		194		194			3.7

5	5	5	5	5	5	5	5	5	5	4.1		
2230		2180		2180		2180		2180		4.2		
100		100		100		100		100		4.3		
3320		3390		3390		3390		3390		4.4		
3898		4006		4006		4006		4006		4.5		
2070		2070		2070		2070		2070		4.7		
2085		2085		2085		2085		2085		4.7.1		
919		919		919		919		919		4.8		
500		500		500		500		500		4.12		
3011		2898		3006		2989		3006		4.19		
2011		1898		2006		1989		2006		4.20		
1050 ❖		1116		1116		1116		1116		4.21		
40	80	1000	40	80	1000	40	80	1000	40	100	1000	4.22
2A		2A		2A		2A		2A		4.23		
907		977		977		977		977		4.24		
70		70		70		70		70		4.31		
100		100		100		100		100		4.32		
1000 x 1200		1000 x 1200		1000 x 1200		1000 x 1200		1000 x 1200		4.33		
3340		3228		3336		3228		3336		4.34		
3340		3228		3336		3228		3336		4.34.1		
3463		3350		3458		3350		3458		4.34.2		
1685		1577		1685		1577		1685		4.35		
0		0		0		0		0		4.36		
1798		1776		1820		1776		1820		4.41		
557		557		557		557		557		4.42		
484		484		484		484		484		4.43		

16	16	16	16	16	16	16	16	16	16	5.1
16	16	16	16	16	16	16	16	16	16	5.1.1
0.43	0.59	0.41	0.60	0.41	0.60	0.40	0.58	0.40	0.58	5.2
0.50	0.47	0.46	0.40	0.46	0.40	0.47	0.40	0.47	0.40	5.3
3406	3680	3337	3646	3337	3646	3260	3603	3294	3637	5.5
11415	11690	11355	11664	11346	11655	11269	11612	11304	11647	5.6
11	16	10	15	10	15	9	14	9	15	5.7
25	35	23	35	23	36	31	34	22	36	5.8
4.6	4.1	4.6	4.1	4.6	4.1	4.6	4.1	4.6	4.1	5.9
Electric		Electric		Electric		Electric		Electric		5.10

2x 5.0		2x 5.0		2x 5.0		2x 5.0		2x 5.0		6.1
12		12		12		12		12		6.2
DIN 43531-A		DIN 43531-A		DIN 43531-A		DIN 43531-A		DIN 43531-A		6.3
48	750	48	625	48	750	48	625	48	750	6.4
962	1064	813	899	962	1064	813	899	962	1064	6.5
4.2		4.7		4.7		5.5		5.2		6.6

Electric transmission		Electric transmission		Electric transmission		Electric transmission		Electric transmission		8.1
180		180		180		180		180		10.1
40		40		40		40		40		10.2
16.8		16.8		16.8		16.8		16.8		10.3
69		69		69		69		69		10.7
Pin		Pin		Pin		Pin		Pin		10.8

EQUIPMENT & WEIGHT: Weights (line 2.1) are based on the following specifications: Complete truck with 3 320 mm Vista Plus (J1.5-1.6XNT) or 3 390 mm Vista (J1.8-2.0XNT) 2-stage limited free lift mast, 910 mm hook type carriage with load backrest and 1 000 mm forks. Overhead guard and pneumatic shaped solid drive and steer tyres.

TRUCK DIMENSIONS

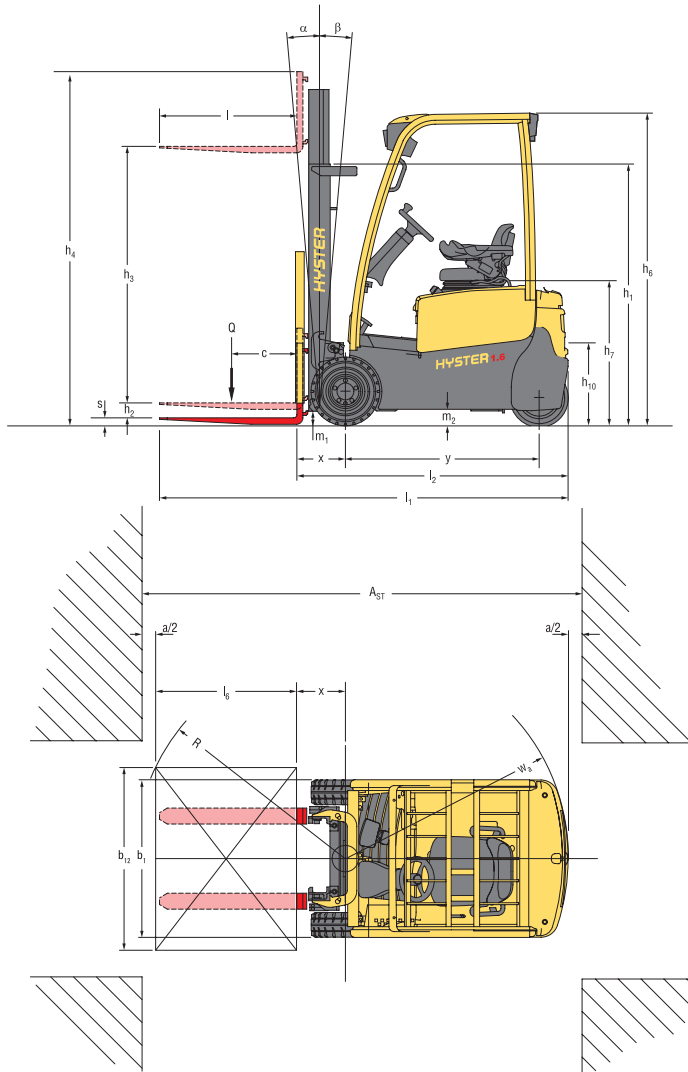

- = Centre of gravity of unladen truck
- A_{st} = $Wa + R + a$ (see lines 4.34.1 & 4.34.2)
- $R = \sqrt{(l_6 + x)^2 + \left(\frac{b_{12} - b_{13}}{2}\right)^2}$
- a = Minimum operating clearance
(VDI standard = 200 mm
BITA recommendation = 300 mm)
- l₆ = Load length

NOTE:

Specifications are affected by the condition of the vehicle and how it is equipped, as well as the nature and condition of the operating area. Inform your dealer of the nature and condition of the intended operating area when purchasing your Hyster Truck.

- Max. battery
- ¶ Bottom of forks
- Full suspension seat specified. Standard Hood specified. 953mm with raised hood.
- + Without load backrest
- add 32mm with load backrest
- h₆ subject to +/- 5 mm tolerance
- ◇ maximum flow set through dash display.
- △ HiP performance
- ▲ min/max
- ❖ Overall width 1116 mm with required 200/50-10 tyres fitted for masts 5000mm and over.
- ❖ Value shown for vertical battery removal; horizontal battery removal has 90 mm of clearance at center of wheelbase.
- ◆ Stacking aisle width (lines 4.34.1 & 4.34.2) is based on the VDI standard calculation as shown on illustration. The British Industrial Truck Association recommends the addition of 100 mm to the total clearance (dimension a) for extra operating margin at the rear of the truck.
- † Gradeability figures (lines 5.7 & 5.8) are provided for comparison of tractive performance, but are not intended to endorse the operation of the vehicle on the stated inclines. Follow instructions in the operating manual regarding operation on inclines.
- ⊙ LPAZ, measured according to the test cycles and based on the weighting values contained in EN12053

MAST TABLES KEY:

- ★ Add 721mm with load backrest extension
- ▲ Deduct 723mm with load backrest extension.
- * Add 723mm with load backrest extension.
- ✱ Add 656mm with load backrest extension.
- ❖ Add 655mm with load backrest extension
- Deduct 655mm with load backrest extension.
- ◆ Tilt speed reduced to 1° per second by mechanical tilt speed restrictors for mast heights 5000mm and above.

RATED CAPACITIES

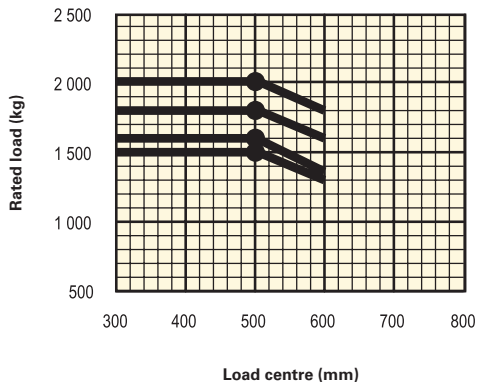

Load centre
Distance from front forks to centre of gravity of load.

Rated load
Based on vertical masts up to 3 430mm to top of forks.

NOTICE

Care must be exercised when handling elevated loads. When the carriage and/or load is elevated, truck stability is reduced. It is important that mast tilt in either direction be kept to a minimum when loads are elevated

Operators must be trained and must read, understand and follow the instructions contained in the Operating Manual.

All values are nominal values and they are subject to tolerances. For further information, please contact the manufacturer.

Hyster products might be subject to change without notice.

Lift trucks illustrated may feature optional equipment. Values may vary with alternative configurations.

CE Safety:

This truck conforms to the current EU requirements.

MAST AND CAPACITY INFORMATION

Values shown are for standard equipment. When using non-standard equipment these values may change. Please contact your Hyster dealer for information.

VISTA PLUS MASTS J1.5-1.6XNT

	Maximum Fork Height (mm) (h ₂ + s)	Back Tilt	Overall Lowered Height (mm)	Overall Extended Height (mm)	Free lift (top of forks) (mm) (h ₂ + s)
Vista Plus 2-Stage limited free lift	3360	5°	2230	3868 ★	140
	3860	5°	2580	4368 ★	140
	4360	5°	2830	4868 ★	140
	4860	5°	3180	5386 ★	140
Vista Plus 3-Stage full free lift	4600	5°	2080	5108 *	1572 ▲
	4900	5°	2180	5408 *	1672 ▲
	5200 ♣	5°	2330	5708 *	1822 ▲
	5500 ♣	5°	2430	6008 *	1922 ▲

VISTA MASTS J1.5-2.0XNT

	Maximum Fork Height (mm) (h ₂ + s)	Back Tilt (°)	Overall Lowered Height (mm)	Overall Extended Height (mm)	Free lift (top of forks) (mm) (h ₂ + s)
Vista 2-Stage limited free lift	3432	5°	2180	4006 *	140
	3932	5°	2530	4506 *	140
	4432	5°	2780	5006 *	140
	4932	5°	3130	5506 *	140
Vista 2-Stage full free lift	3218	5°	2080	3728 ♣	1505 ♣
	3718	5°	2330	4228 ♣	1755 ♣
	4338	5°	2680	4847 ♣	2105 ♣
Vista 3-Stage limited free lift	4600	5°	2030	5175 ♣	1455 ♣
	4900	5°	2130	5375 ♣	1555 ♣
	5200 ♣	5°	2280	5775 ♣	1705 ♣
	5500 ♣	5°	2380	6075 ♣	1805 ♣

J1.5-1.6XNT - Vista Plus capacity chart in kg @ 500 mm load centres

	Max fork height (mm)	Pneumatic Shaped Solid Tyres							
		WITHOUT sideshift				WITH integral sideshift			
		J1.5XNT (SWB)	J1.6XNT (SWB)	J1.6XNT (MWB)	J1.6XNT (LWB)	J1.5XNT (SWB)	J1.6XNT (SWB)	J1.6XNT (MWB)	J1.6XNT (LWB)
Vista Plus 2-Stage limited free lift	3360	1 500	1 600	1 600	1 600	1 500	1 600	1 600	1 600
	3860	1 500	1 600	1 600	1 600	1 500	1 600	1 600	1 600
	4360	1 480	1 580	1 580	1 580	1 480	1 580	1 580	1 580
	4860	1 390	1 490	1 490	1 500	1 390	1 490	1 490	1 500
Vista Plus 3-Stage full free lift	4600	1 450	1 540	1 540	1 550	1 450	1 540	1 540	1 550
	4900	1 390	1 490	1 490	1 500	1 390	1 490	1 490	1 500
	5200 ♣	1 340	1 430	1 320	1 330	1 340	1 360	1 250	1 260
	5500 ♣	1 280	1 130	1 060	1 080	1 240	1 070	1 000	1 010

J1.5-1.6XNT - Vista Plus capacity chart in kg @ 600 mm load centres

	Max fork height (mm)	Pneumatic Shaped Solid Tyres							
		WITHOUT sideshift				WITH integral sideshift			
		J1.5XNT (SWB)	J1.6XNT (SWB)	J1.6XNT (MWB)	J1.6XNT (LWB)	J1.5XNT (SWB)	J1.6XNT (SWB)	J1.6XNT (MWB)	J1.6XNT (LWB)
Vista Plus 2-Stage limited free lift	3360	1 300	1 450	1 450	1 450	1 300	1 450	1 450	1 440
	3860	1 300	1 450	1 450	1 450	1 300	1 450	1 450	1 450
	4360	1 280	1 430	1 430	1 430	1 280	1 430	1 430	1 430
	4860	1 210	1 350	1 350	1 360	1 210	1 350	1 350	1 360
Vista Plus 3-Stage full free lift	4600	1 300	1 450	1 450	1 450	1 300	1 450	1 450	1 440
	4900	1 250	1 400	1 400	1 400	1 250	1 400	1 400	1 400
	5200 ♣	1 210	1 350	1 350	1 360	1 210	1 350	1 340	1 350
	5500 ♣	1 160	1 300	1 300	1 310	1 160	1 290	1 250	1 260

♣ Tilt speed reduced to 1° per second by mechanical tilt speed restrictors for mast heights 5000mm and above.

NOTE: The rated capacities shown are for masts in a vertical position on trucks equipped with standard or sideshift carriage and nominal length forks. Masts above the maximum fork heights shown in the mast table are classified as high lift and, depending on the tyre/tread configuration may require reduced capacity, restricted back tilt or wide tread.

MAST AND CAPACITY INFORMATION

Values shown are for standard equipment. When using non-standard equipment these values may change. Please contact your Hyster dealer for information.

J1.5-2.0XNT - Vista capacity chart in kg @ 500 mm load centres

	Max fork height (mm)	Pneumatic Shaped Solid Tyres															
		WITHOUT sideshift								WITH integral sideshift							
		J1.5XNT (SWB)	J1.6XNT (SWB)	J1.6XNT (MWB)	J1.6XNT (LWB)	J1.8XNT (MWB)	J1.8XNT (LWB)	J2.0XNT (MWB)	J2.0XNT (LWB)	J1.5XNT (SWB)	J1.6XNT (SWB)	J1.6XNT (MWB)	J1.6XNT (LWB)	J1.8XNT (MWB)	J1.8XNT (LWB)	J2.0XNT (MWB)	J2.0XNT (LWB)
Vista 2-Stage limited free lift	3432	-	1 600	1 600	1 600	1 800	1 800	2 000	2 000	-	1 600	1 600	1 600	1 800	1 800	1 990	1 990
	3932	-	1 600	1 600	1 600	1 800	1 800	2 000	2 000	-	1 600	1 600	1 600	1 800	1 800	1 980	1 980
	4432	-	1 580	1 580	1 580	1 780	1 780	1 980	1 980	-	1 580	1 580	1 580	1 780	1 780	1 950	1 950
	4932	-	1 490	1 490	1 500	1 580	1 580	1 570	1 560	-	1 490	1 490	1 500	1 540	1 540	1 520	1 520
Vista 2-Stage full free lift	3218	1 500	1 600	1 600	1 600	1 800	1 800	2 000	2 000	1 500	1 600	1 600	1 600	1 800	1 800	2 000	2 000
	3718	1 500	1 600	1 600	1 600	1 800	1 800	2 000	2 000	1 500	1 600	1 600	1 600	1 800	1 800	1 990	1 990
	4338	1 500	1 600	1 600	1 600	1 800	1 800	2 000	2 000	1 500	1 580	1 600	1 600	1 800	1 800	1 960	1 980
Vista 3-Stage full free lift	4600	-	1 570	1 570	1 570	1 770	1 770	1 970	1 970	-	1 550	1 570	1 570	1 770	1 770	1 930	1 950
	4900	-	1 520	1 520	1 520	1 710	1 710	1 780	1 910	-	1 510	1 520	1 520	1 710	1 710	1 720	1 880
	5200 ♣	-	1 380	1 260	1 280	1 650	1 650	1 490	1 670	-	1 320	1 200	1 210	1 650	1 650	1 440	1 600
	5500 ♣	-	1 090	1 000	1 030	1 590	1 440	1 250	1 420	-	1 030	950	970	1 550	1 370	1 200	1 360

J1.5-2.0XNT - Vista capacity chart in kg @ 600 mm load centres

	Max fork height (mm)	Pneumatic Shaped Solid Tyres															
		WITHOUT sideshift								WITH integral sideshift							
		J1.5XNT (SWB)	J1.6XNT (SWB)	J1.6XNT (MWB)	J1.6XNT (LWB)	J1.8XNT (MWB)	J1.8XNT (LWB)	J2.0XNT (MWB)	J2.0XNT (LWB)	J1.5XNT (SWB)	J1.6XNT (SWB)	J1.6XNT (MWB)	J1.6XNT (LWB)	J1.8XNT (MWB)	J1.8XNT (LWB)	J2.0XNT (MWB)	J2.0XNT (LWB)
Vista 2-Stage limited free lift	3432	-	1 450	1 450	1 450	1 600	1 600	1 800	1 800	-	1 450	1 450	1 450	1 600	1 600	1 780	1 780
	3932	-	1 450	1 450	1 450	1 600	1 600	1 800	1 800	-	1 450	1 450	1 450	1 600	1 600	1 780	1 770
	4432	-	1 430	1 430	1 430	1 580	1 580	1 780	1 780	-	1 430	1 430	1 430	1 580	1 580	1 760	1 760
	4932	-	1 350	1 350	1 360	1 500	1 500	1 570	1 560	-	1 340	1 340	1 350	1 500	1 500	1 520	1 520
Vista 2-Stage full free lift	3218	1 300	1 450	1 450	1 450	1 600	1 600	1 800	1 800	1 300	1 450	1 450	1 450	1 600	1 600	1 790	1 790
	3718	1 300	1 450	1 450	1 450	1 600	1 600	1 800	1 800	1 300	1 450	1 450	1 450	1 600	1 600	1 790	1 780
	4338	1 300	1 450	1 450	1 450	1 600	1 600	1 800	1 800	1 300	1 440	1 450	1 450	1 600	1 600	1 780	1 770
Vista 3-Stage full free lift	4600	-	1 450	1 450	1 450	1 600	1 600	1 800	1 800	-	1 420	1 420	1 420	1 570	1 570	1 750	1 740
	4900	-	1 420	1 420	1 420	1 570	1 570	1 770	1 770	-	1 420	1 420	1 420	1 570	1 570	1 750	1 740
	5200 ♣	-	1 370	1 370	1 380	1 520	1 520	1 720	1 710	-	1 370	1 370	1 370	1 520	1 520	1 700	1 690
	5500 ♣	-	1 320	1 260	1 280	1 470	1 470	1 490	1 660	-	1 310	1 200	1 210	1 470	1 470	1 440	1 590

NOTE: The rated capacities shown are for masts in a vertical position on trucks equipped with standard or sideshift carriage and nominal length forks. Masts above the maximum fork heights shown in the mast table are classified as high lift and, depending on the tyre/tread configuration may require reduced capacity, restricted back tilt or wide tread.

PRODUCT FEATURES

DEPENDABILITY

- Robust and proven masts give high visibility and reliable, high performance lifting.
- Steel hoods and covers provide resistance to impact damage and general wear and tear.
- AC motor technology on traction and hoist allows the truck to work more reliably and for longer shifts, reducing downtime significantly.
- Hall-Effect sensors on transmission replace internal encoder bearing, making the truck more reliable and decreasing downtime.
- IP54 enclosed traction motors and IP65 protection of controls, prevent ingress of water and dust particles, reducing the probability of truck breakdown.
- Use of O-Ring face seals in the hydraulic system, sealed electrical connectors and LED lights, replacing light bulbs, gives maximum uptime over the product life cycle.

- E-steering system simplifies and shortens the hydraulic circuits in the truck, simplifying maintenance and reducing the opportunity for leaks.

PRODUCTIVITY

- Front wheel AC drive motors provides smooth acceleration and excellent travel and torque performance. This is combined with powerful acceleration and auto regenerative braking to deliver precise efficient load handling.
- Compact chassis length and robust steer axle allow tight turning circles for excellent maneuverability in working aisles or congested loading/ unloading bays.
- E-steering increases productivity while maintaining excellent battery life.
- E-braking system provides service braking to be achieved using regenerative motor braking, offering increased energy efficiency, reduced energy consumption and increases uptime.

PRODUCT FEATURES

- Battery capacity and truck wheel base can be matched to the application, optimising performance, maneuverability and battery shift life.
- Energy Low (eLo) settings are designed to assure full shift of work on each charge.
- High Performance (HiP) settings give impressive truck performance.
- Easy side extraction battery removal with 180°-fold back door, allows more uninterrupted uptime with a fast, simple exchange process to keep trucks on the move.

ERGONOMICS

- Generous foot space, intuitive pedal arrangement and low step and hood heights offer a comfortable working space for the driver. This means on/off access and driving in reverse cause less fatigue over long shifts.
- Full suspension seat with 80mm of travel reduces truck vibrations, creating a smoother ride for the operator. Swivel seat option for operations requiring frequent reversing.
- Optional IntelligentBelt™ interlock system prevents truck from traveling until operator is seated with seat belt securely fastened to ensure that seat belt is used correctly.
- Multiple choices of Hydraulic controls:
 - Seat side manual lever control with new design manual levers for superb handling productivity.
 - The latest design adjustable TouchPoint™ armrest module with built in hydraulic controls, integrated directional control, emergency off switch and horn offers the ultimate in comfort and control.
 - New design ergonomic joystick with integrated hydraulic controls including direction change, return to set tilt and clamping, designed and positioned to provide maximum comfort for operator.
- Synchronous steering maintains the steering knob at the preferred position for the driver when driving straight increasing operator comfort and reduces fatigue.
- Steer Column is infinitely adjustable via adjustable gas spring support, optional height adjustment available.
- The memory tilt option allows the steering column to be released to the most vertical position to allow the operator to get off the truck easily. When getting back on the truck, the operator simply pulls the steer column back to the preset position.
- A choice of weather protection options promotes a comfortable working environment, whatever the conditions.

LOW COST OF OWNERSHIP

- The right balance of performance, manoeuvrability and battery provision, matched to the application needs gives productivity and throughput at less cost.
- The Vehicle System Manager (VSM) allows adjustment of truck performance parameters as well as monitoring key functions, leading to application matched performance and low maintenance.
- Durable, quality components mean long term reliability and lower maintenance costs. Virtually maintenance free components such as brushless AC motors mean that Hyster Electrics require a full service check only after 1 000 hours.
- In-built thermal protection on traction motors and advanced cooling system protect truck components, leading to reduced maintenance costs.
- Fast delivery of diagnostic information allows precise troubleshooting, easy maintenance planning and lower costs.
- E-braking and Steering systems reduce 'wear parts' and are less vulnerable to ingress of dirt and floor debris, reducing maintenance costs.

SERVICEABILITY

- Access to diagnostic information via the display or plug-in point on the steering column allows engineers to monitor truck conditions and plan maintenance requirements.
- Easily removable 2-piece floor plate provides easy access to power contactor, fuses and relays.
- Automatic park brake system can be released manually by activating lever arrangement underneath floor plates, reducing downtime.
- Motor, pump, controller and oil tank are located in the counterweight and are easily accessible, requiring only 2 thumb screws to be removed.

HYSTER® DEALERS



Contact your nearest Hyster Dealership
by visiting www.hyster.com.au



Contact your local Hyster Dealer

HYSTER ASIA PACIFIC

1 Bullecourt Avenue, Milperra NSW, Australia 2214

Tel: +61 (2) 9795 3800 Fax: +61 (2) 9792 8484

No. 49, Jalan Astaka V8/84A, Bukit Jelutong,
40150 Shan Alam, Selangor, Malaysia

Tel: +603 7831 3385

hyster.com/pacific/en-au

hyster.com/asia/en-sg



/Hysterasiapacific



@Hyster_AP

 is a Registered Trademark.

HYSTER is a Registered Trademark. STRONG PARTNERS. TOUGH TRUCKS. EZXCHANGE, HSM and VISTA are trademarks in the United States and certain other jurisdictions. © Hyster Asia Pacific 2016. All rights reserved. Printed in Australia. Specifications and details in this brochure are subject to change without prior notification. Please consult with your Hyster dealer for the most up to date information and to confirm exact capacities.
3990025 Rev. 08-05/16-TLC

HYSTER.COM.AU