



**Alternative Fuel.  
Which is Right for You?**





## ***Introduction***

As more alternative fuel and hybrid options emerge, it can be difficult to grasp or decipher the nuances between the benefits and challenges that each option provides. While moving to a more eco-friendly and sustainable solution, the lifting, traveling and load capacity of lift trucks must be evaluated simultaneously, and a proper balance of cost, energy efficiency and productivity considered.

## ***Alternative Options***

There are a number of alternate power solutions to address the needs for greater fuel efficiency and increased environmental stewardship. In some cases, technology is needed to meet governmental regulations on emissions. Fuel cell technology continues to gain more lift truck placements as it provides significant benefits and quick refueling. Compressed Natural Gas (CNG) offers combustion engines a cleaner-burning, more eco-friendly fuel. Hybrid technology combines the two traditional power solutions by coupling together a combustion engine with an electric motor. In order to meet government regulations for diesel-powered lift trucks, two solutions are available in Selective Catalytic Reduction (SCR) and Exhaust Gas Recirculation (EGR).

These technologies each provide unique ways of working in concert with existing engine technologies or circumventing traditional propulsion models entirely to deliver better fuel efficiency and greater environmental awareness, while also addressing many of the maintenance, productivity and performance concerns of the material handling industry.

## ***Alternative Options: Explained***

While alternative fuel and power options abound for lift trucks, not all of these alternatives are applicable for every lift truck application. It is always important to understand the needs of the specific material handling operation and the demands that will be made on the truck — performance, operation cycle, lift capacity and more — before selecting which type of lift truck and power source to utilize. As with any technology, there are positive features and attributes, as well as challenges that could give some material handling operations pause in selecting a particular option for their lift trucks.

## ***Fuel Cell Technology***

Fuel cells are a quickly-growing, popular alternative source of power for lift trucks. The basics of fuel cell technology often begin with the cell itself being categorized by the electrolyte, which is the material that separates the two terminals and acts as the vehicle for the ion exchange that ultimately generates the electrical current. While the electrolyte is important to the process, it is usually the fuel that is more often



referred to, with hydrogen being the most prominent. The fuel cell combines the fuel with oxygen electrochemically, which eliminates the need for burning or combustion to take place in order to generate the power. The result is electricity and a by-product. The by-product of this combination is simply water, which eliminates nearly all pollutants and makes the fuel cell one of the most efficient, eco-friendly power sources available. While a battery stores power and has to be recharged, a fuel cell creates its own electricity, as long as it has a supply of fuel and air to use in conjunction with the electrolyte.

For lift trucks, fuel cell technology is growing and has been very successful for those operations who have implemented the technology into their lift truck fleets in Class I, II and III applications. Lift trucks powered by fuel cells are essentially the same as battery-powered lift trucks, with some minor modifications. The fuel cell replaces the battery. In effect, the fuel cell acts as a battery that can be quickly and easily refilled. A battery, on the other hand, requires 8-16 hours to recharge and cool down. So, multi-shift applications often require multiple batteries per truck, and a change of batteries to refuel. Fuel cell technology is currently most effective in high-volume applications where there would be a high battery change need, using valuable time and labor. This technology provides an operating environment with zero pollutant emissions (with water as the by-product) and relatively low noise levels. Fuel cell lift trucks can typically operate for two to three times as long as battery-powered trucks, and refueling fuel cell-powered trucks takes approximately 3-10 minutes, depending on the size of the fuel tank.

One of the main prohibitive factors to widespread use of fuel cell technology is the infrastructure. While it continues to grow, there is a significant up-front cost to switching to fuel cell-powered lift trucks. The equipment is needed to compress, store and then dispense the hydrogen fuel to the lift trucks. While material handling operations provide an ideal operation for a central source for refueling compared to the infrastructure needed to make fuel cells widespread in the automotive industry, the cost could be prohibitive for some companies and applications. At this point, the technology works best for large fleets of at least 30 trucks to spread out the cost of the infrastructure. In addition to infrastructure cost, the cost of the fuel cells is also high, much more than the cost of multiple batteries and a charger.

Just as electric lift trucks see limitations to the applications in which they operate best, fuel cell lift trucks also work best in moderate capacity applications because the fuel cell can generate only so much power. As the technology progresses and the corresponding power generated increases, fuel cell lift trucks may enter more and more applications in the material handling industry. As the infrastructure matures and becomes less cost prohibitive, hydrogen fuel cell technology could make significant inroads into the material handling industry.

#### *Compressed Natural Gas (CNG)*

While not entirely new to the lift truck industry, compressed natural gas (CNG) provides another alternative fuel option for ICE lift trucks. The CNG-powered truck eliminates or reduces a number of the downsides of traditional combustion engines.



CNG generally delivers a lower fuel cost against traditional ICE fuel options, and the domestic availability of natural gas is relatively high, resulting in less price fluctuation or volatility. The availability of the fuel stems from significant domestic sources with a lot of new recent discoveries. In addition to the infrastructure and availability of natural gas, it also burns cleaner than diesel and LPG.

While the domestic availability and infrastructure supports the spread of CNG-powered lift trucks, the on-site infrastructure and general technology conversion can be a difficult up-front concern for many operations. Even without the infrastructure costs, the capital expense to cover the increased cost of the actual CNG-equipped lift trucks from the manufacturer can be overwhelming. As with several of the other alternative technologies, CNG-powered lift trucks can be limited in the Class and applications in which they are able to operate due to performance losses compared to LPG-powered ICE trucks. The performance loss of 5 to 15 percent is directly related to the lower energy density of CNG.

CNG lift trucks also face difficulties that inherently come with the change of fuel. Refilling the lift trucks is made difficult by the fact that the tanks cannot be exchanged on the truck, ultimately leading to less efficient operational practices and potentially having to tow a lift truck back to the fueling station if it runs out. This fueling challenge is further complicated by the fact that the lift truck's run time is shortened by lower fuel efficiency, leading to larger fuel tanks on CNG-powered trucks. CNG-powered lift trucks also take a long time to refuel, unless the user has invested in very expensive refueling equipment. The rearward visibility of the operator might be impacted by the large fuel tank.

#### *Hybrid Technology*

Hybrid technology is seeing wider acceptance in the auto industry, which is evidenced by the growing number of hybrid models available from a range of different manufacturers.

The hybrid technology being applied in the auto industry can be simplified and put into two different categories. One approach is installing an electric motor in a direct drive mode between the engine and the transmission. This motor then provides the engine the ability to not only shut down at traffic stops or other similar stops, but also easily restart when the accelerator is applied. That ability for engines to shut down, combined with the comparatively smaller engine, may improve the overall vehicle fuel economy.

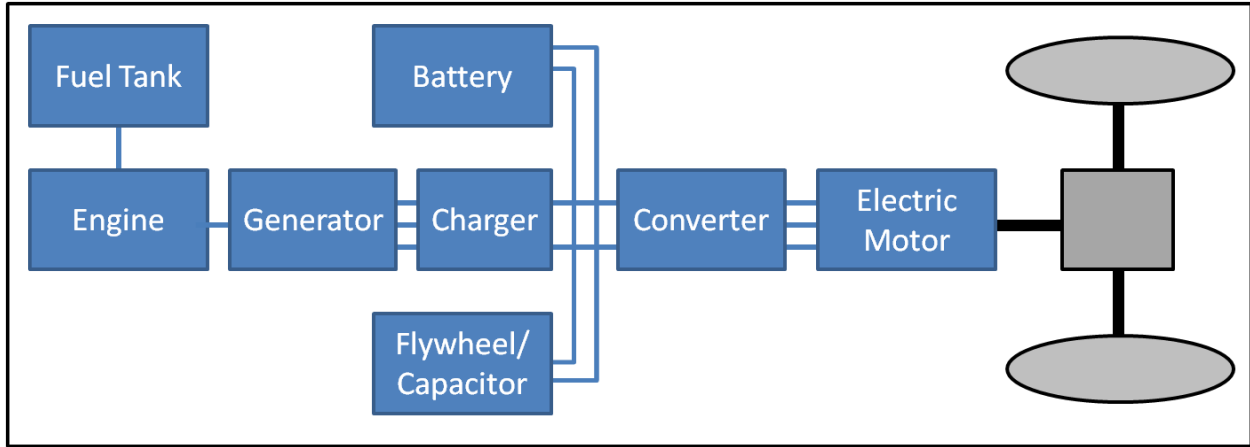

**Basic Example of Direct Drive Hybrid Technology**

The second simplified approach to hybrid technology involves an electric motor installed in the driveline, but this time not as a direct drive with the engine. This approach is often more complex, with the engine and the motor being independently connected to the transmission, which is then able to mix the power from the engine and the motor however the vehicle's computer deems appropriate. This method of hybrid technology typically yields a higher level of efficiency when compared to the former approach. However, the complexity of this system can cause problems and has a higher cost associated with it than the more simplistic direct drive approach.

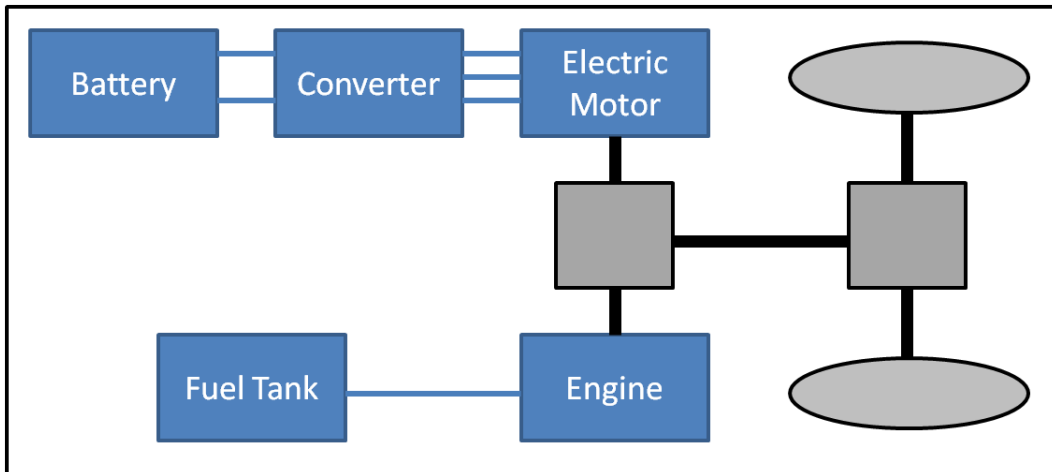

**Basic Example of Non-Direct Drive Hybrid Technology**

As the technology matures and the various approaches to implementing the technology progress, more and more lift truck manufacturers will test and develop hybrid solutions for appropriate material handling



applications. While the technology is eco-friendly, hybrids must still answer the lift truck value proposition – a proposition that is different and more nuanced than that of the auto industry.

For the auto industry, hybrid technology's primary focus is the improvement of fuel economy when the engine is running at very light loads, such as steady highway speeds. By contrast, electric lift truck operations already have the benefit of high fuel efficiency. In most cases, the primary focus for lift trucks is the ability to operate electric trucks without the need for battery changes. The truck can be equipped with a small engine that drives a generator to keep the battery charged.

One final difficulty for hybrid technology is found in the fact that a hybrid lift truck would still require an internal combustion engine. Even with less use, the lift truck would require maintenance of an engine, along with that of the electric motor. Ultimately, the long-term maintenance cost associated with a complex hybrid system should be weighed against the potential fuel economy improvements.

#### *SCR & EGR: Solutions for EPA Tier 4 Interim Diesel Emissions Regulations*

Beginning in January 2011, the EPA Tier 3 and European Union (EU) Stage IIIA off-highway diesel engine emissions regulations for large engines (above 174 hp or 130 kW) were replaced. The new Tier 4 Interim/Stage IIIB emissions regulations require reduced Particulate Matter (PM) exhaust emissions of 90 percent and lower Oxides of Nitrogen (NOx) exhaust emissions of 45 percent compared to Tier 3/Stage IIIA standards.

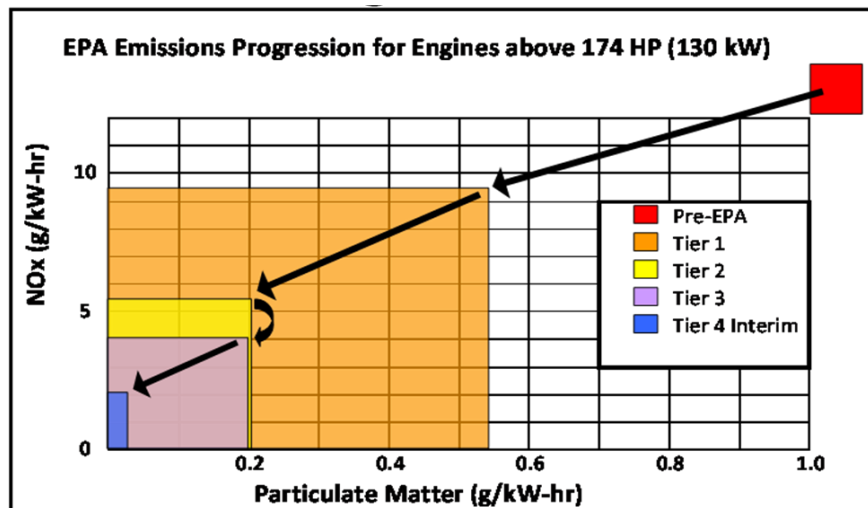

Progression of Diesel Engine Emission Standards

NOx, a term for the nitrogen oxide air pollutants NO and NO<sub>2</sub> emissions, is a regulated gaseous emission and primary contributor to smog. PM is a regulated diesel emission composed primarily of carbon soot and other combustion byproducts.



Carbon dioxide (CO<sub>2</sub>), a possible contributor to climate change, is not regulated by the EPA for Tier 4 Interim/Stage IIIB emissions regulations. CO<sub>2</sub> is a natural byproduct of diesel combustion and its emission can only be reduced by lowering fuel consumption.

Diesel engine manufacturers are utilizing two main technology options to reduce NOx and PM to the required levels; each with its merits and drawbacks. Both solutions provide added level of fuel efficiency and, by meeting the tighter regulations, are more eco-friendly than previous engines.

One method is known as Selective Catalytic Reduction (SCR). SCR injects a reagent known as Diesel Exhaust Fluid (DEF, also known as urea) into the exhaust gas flow, both of which then mix in a catalytic converter, reducing or neutralizing NOx down harmless nitrogen and oxygen particles. The DEF reagent is a 32.5 percent urea and 67.5 percent water mixture and is commercially available. Depending on the engine load factor, urea consumption is three to five gallons for every 100 gallons of diesel fuel used, but provides no energy content. Lift trucks utilizing this technology require separate DEF tanks and regular fill-ups, creating additional costs for the user.

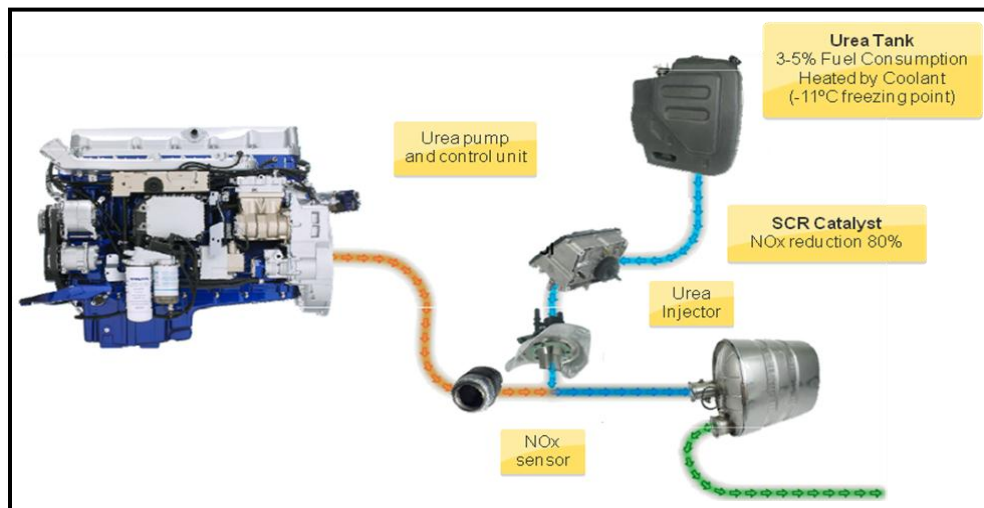

**Selective Catalytic Reduction (SCR) Process**

The second technology, Exhaust Gas Recirculation (EGR), dilutes the amount of oxygen in the combustion chamber by mixing the intake air charge with cooled exhaust gas. The process lowers the combustion peak temperature, reducing the formation and amount of NOx produced by the engine. This lower temperature also increases PM, which is then filtered out, often through the use of a Diesel Particulate Filter (DPF).

Both SCR and EGR require ultra-low sulfur diesel (ULSD) fuel and low-ash lubricating oils to function properly and take full advantage of their efficiency gains.



The SCR solution requires regular refilling of an on-board DEF tank, and can add time and additional cost to the operation of SCR-equipped lift trucks. The DEF can cost from \$1.50 to \$4 per gallon. Unlike SCR engines, the EGR and DPF solution does not require urea fluid to meet the emissions standards. The EGR solution does require new parts to be added to the engine, which can be time-consuming in a retrofit application. The SCR solution adds additional parts for the DEF injector, pump and tank, but does not require any engine work to be done for the system to function.

	Tier 3		EGR + DPF		SCR	
<b>Equipment Cost:</b>						
New engine parts	+	No	-	EGR cooler + valve	+	No
Exhaust system	+	No	-	DPF	-	SCR Catalyst
Additional parts	+	No	+	No	-	DEF injector DEF pump DEF tank
<b>Operating Cost:</b>						
ULSD	+	No	-	Yes	-	Yes
Fuel efficient		Baseline	+	Yes 5%	+	Yes 3-5%
Additional fluids	+	No	+	No	-	Yes 3-5% DEF
Low ash oil	+	No	-	Yes	-	Yes
<b>Daily Hassle:</b>						
Additional fluids & handling	+	No	+	No	-	Yes, refill DEF
Additional infrastructure	+	No	+	No	-	Yes, DEF tanks
DPF Regeneration	+	No	-	<10% of applications	+	No

**User Impact Comparison of Tier 3/Stage IIIA, EGR + DPF and SCR Technologies**

Achieving low levels of emissions for Tier 4 Interim/Stage IIIB required a major investment in engine and new system technology by both engine and equipment manufacturers. While Tier 4 Interim/Stage IIIB powered equipment is inherently more expensive than Tier 3/Stage IIIA trucks, the cost of achieving compliance with the SCR or EGR solutions can be offset by the lower overall operating costs. In some





cases, operators may experience improved equipment productivity together with the benefit of cleaner, quieter operation and may also find reduced fuel costs.

**Conclusion**

While ICE and electric battery-powered lift trucks remain the most cost-effective solutions for a majority of material handling applications, companies should always be investigating, testing and evaluating new methods and technologies to potentially reduce their operating costs and their impact on the environment. By understanding the various new technologies and their strengths and weaknesses, businesses will be better able to analyze their operations and potential solutions for their material handling needs.

		Alternative Fuel Options			
		CNG	Fuel Cell	Hybrid	EGR/SCR
Conventional Fuel Options	LPG/Gas – Sit Down Rider	X		X	
	Diesel – Sit Down Rider	X		X	X
	Electric – Sit Down Rider		X	X	
	Electric – Narrow Aisle		X		
	Electric – Pallet Truck		X		

**Alternative Fuel Options: Where They Work**

Whether or not a company has a formal evaluation process for its material handling operations, it can be helpful to discuss operational challenges and potential solutions with a lift truck manufacturer. Manufacturers are able to provide valuable insight into the technology and lift truck options that would be best suited for an operation’s particular application. Partnering with a reliable, leading lift truck manufacturer will further strengthen a company’s chances of achieving its overall goals.